

# The Unico System<sup>®</sup>

## VERTICAL AHU INSTALLATION MANUAL

BULLETIN 30-015

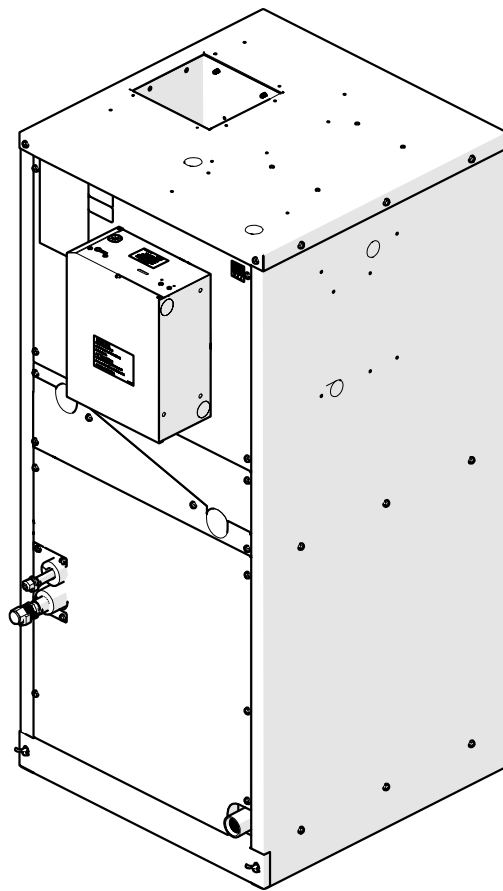

# IMPORTANT!

## Please read before installation

**For safe installation and trouble-free operation, you must:**

- Carefully read this instruction booklet before beginning.
- Follow each installation or repair step exactly as shown.
- The unit must be installed in accordance with all local, state, and national wiring regulations.
- Pay close attention to all warning and caution notices given in this manual.
- The unit must be supplied with a dedicated electrical line.
- Unit maximum operating elevation of 15,000 ft (4572 m)

### **If necessary, get help**

These instructions are all you need for most installation sites and maintenance conditions.

If you require additional help for a special problem, contact our customer service department for additional instructions.

### **In case of improper installation**

The manufacturer shall in no way be responsible for improper installation or maintenance service, including failure to follow the instructions in this document.

### WARNING

When wiring



**ELECTRICAL SHOCK CAN CAUSE SEVERE PERSONAL INJURY OR DEATH. ONLY A QUALIFIED, EXPERIENCED ELECTRICIAN SHOULD ATTEMPT TO WIRE THIS SYSTEM**

- Do not supply power to the unit until all wiring and tubing are completed or reconnected and checked, to ensure the grounding.
- Highly dangerous electrical voltages are used in this system. Carefully refer to the wiring diagram and these instructions when wiring.

Improper connections and inadequate grounding can cause **accidental injury and death.**

- **Ground the unit** following local electrical codes.
- The Yellow/Green wire cannot be used for any connection different from the ground connection.
- Connect all wiring tightly. Loose wiring may cause overheating at connection points and a possible fire hazard.
- This appliance is not intended for use by persons (including children) with reduced physical, sensory or mental capabilities, or lack of experience and knowledge, unless they have been given supervision or instruction concerning use of the appliance by a person responsible for their safety.
- Children should be supervised to ensure that they do not play with the appliance.
- Means for disconnection must be incorporated in the fixed wiring in accordance with the wiring rules and codes.

Digital copies and additional Bulletins can be found online at: [www.unicosystem.com/resources/](http://www.unicosystem.com/resources/)

DD.2

**WARNING**



**DO NOT USE MEANS TO ACCELERATE THE DEFROSTING PROCESS OR TO CLEAN, OTHER THAN THOSE RECOMMENDED BY THE MANUFACTURER.**



**THE APPLIANCE SHALL BE STORED IN A ROOM WITHOUT CONTINUOUSLY OPERATING IGNITION SOURCES (FOR EXAMPLE: OPEN FLAMES, AN OPERATING GAS APPLIANCE OR AN OPERATING ELECTRIC HEATER.**



**DO NOT PIERCE OR BURN.**

**BE AWARE THAT REFRIGERANTS MAY NOT CONTAIN AN ODOR.**

DD.3.1 – GENERAL

- Pipe-work including piping material, pipe routing, and installation shall include protection from physical damage in operation and service, and be in compliance with national and local codes and standards, such as ASHRAE 15, ASHRAE 15.2, IAPMO Uniform Mechanical Code, ICC International Mechanical Code, or CSA B52. All field joints shall be accessible for inspection prior to being covered or enclosed;
- After completion of filed piping for split systems, the field pipework shall be pressure tested with an inert gas and then vacuum tested prior to refrigerant charging, according to the following requirements;
- The minimum test pressure for the low side of the system shall be the low side design pressure and the minimum test pressure for the high side of the system shall be the high side design pressure, unless the high side of the system, cannot be isolated from the low side of the system in which case the entire system shall be pressure tested to the low side design pressure.
- Field-made refrigerant joints indoors shall be tightness tested. The test method shall have a sensitivity of 5 grams per year of refrigerant or better under a pressure of 0.25 times the maximum allowable pressure. No leak shall be detected.

The Sensor employed in the Refrigerant Detection System (RDS) has a lifetime of 15+ years with no calibration required. In the event of a failed sensor or the end of the sensor lifetime, the failed sensor shall only be replaced with a sensor specified by Unico, Inc.

DD.3.2 – UNVENTILATED AREAS

An unventilated area where the appliance using flammable refrigerants is installed shall be constructed such that should any refrigerant leak, it will not stagnate so as to create a fire or explosion hazard

- If an appliance using A2L refrigerant is connected via an air duct system to one or more rooms with an area less than that of TA<sub>min</sub> as determined from Table 10, that room shall be without continuously operating open flames or other potential ignition sources. A flame-producing device may be installed in the same space if the device is provided with an effective flame arrest;
- Only auxiliary devices approved by Unico, Inc. or declared suitable for use with A2L refrigerant shall be installed in connecting ductwork. The following is a list of auxiliary devices sold by Unico, Inc. approved for use with Unico, Inc. HVAC equipment:

Model Number
WON0202-C
WON0502-C WON0504-C
WON0752-C WON0754-C
WON1002-C WON1004-C
WON1502-C WON1504-C
WON2002-C

DD.3.3 – QUALIFICATION OF WORKERS

Every working procedure that affects safety means shall only be carried out by competent persons who have been trained in these procedures by a national training organization or manufacturers that are accredited to teach the relevant national competency standards that may be set in legislation as listed in UL 60335-2-40 Annex HH.

DD.4 – INFORMATION ON SERVICINGDD.4.2 – CHECKS TO THE AREA

Prior to beginning work on systems containing flammable refrigerants, safety checks are necessary to ensure that the risk of ignition is minimized. For repair to the refrigerating system, DD.4.3 to DD.4.7 shall be completed prior to conducting work on the system.

DD.4.3 – WORK PROCEDURE

Work shall be undertaken under a controlled procedure so as to minimize the risk of flammable gas or vapor being present while the work is being performed.

DD.4.4 – GENERAL WORK AREA

All maintenance staff and others working in the local area shall be instructed on the nature of work being carried out. Work in confined spaces shall be avoided.

DD.4.5 – CHECKING FOR PRESENCE OF REFRIGERANT

The area shall be checked with an appropriate refrigerant detector prior to and during work, to ensure the technician is aware of potentially toxic or flammable atmospheres. Ensure that the leak detection equipment being used is suitable for use with all applicable refrigerants, i.e. non-sparking, adequately sealed or intrinsically safe.

DD.4.6 – PRESENCE OF FIRE EXTINGUISHER

If any hot work is to be conducted on the refrigerating equipment or any associated parts, appropriate fire extinguishing equipment shall be available to hand. Have a dry powder of CO<sub>2</sub> fire extinguisher adjacent to the charging area.

DD.4.7 – NO IGNITION SOURCES

No person carrying out work in relation to a refrigerating system which involves exposing any pipe work shall use any sources of ignition in such a manner that it may lead to the risk of fire or explosion. All possible ignition sources, including cigarette smoking, should be kept sufficiently far away from the site of installation, repairing, removing and disposal, during which refrigerant can possibly be released to the surrounding space. Prior to work taking place, the area around the equipment is to be surveyed to make sure that there are no flammable hazards or ignition risks. “No Smoking” signs shall be displayed.

DD.4.8 – VENTILATED AREA

Ensure that the area is in the open or that it is adequately ventilated before breaking into the system or conducting any hot work. A degree of ventilation shall continue during the period that the work is carried out. The ventilation should safely disperse any released refrigerant and preferably expel it externally into the atmosphere.

DD.4.9 – CHECKS TO THE REFRIGERATING EQUIPMENT

Where electrical components are being changed, they shall be fit for the purpose and to the correct specification. At all times the manufacturer’s maintenance and service guidelines shall be followed. If in doubt, consult the manufacturer’s technical department for assistance.

The following shall be applied to installations using flammable refrigerants:

- The actual refrigerant charge is in accordance with the room size within which the refrigerant containing parts are installed;
- The ventilation machinery and the outlets are operating adequately and are not obstructed;
- If an indirect refrigerating circuit is being used, the secondary circuit shall be checked for the presence of refrigerant;
- Marking to the equipment continues to be visible and legible. Markings and signs that are illegible shall be corrected;
- Refrigerating pipe or components are installed in a position where they are unlikely to be exposed to any substance which may corrode refrigerant containing components, unless the components are constructed of materials which are inherently resistant to being corroded or are suitable protected against being so corroded.

DD.4.10 – CHECKS TO ELECTRICAL DEVICES

Repair and maintenance to electrical components shall include initial safety checks and component inspection procedures. If a fault exists that could compromise safety, then no electrical supply shall be connected to the circuit until it is satisfactorily dealt with. If the fault cannot be corrected immediately but it is necessary to continue operation, an adequate temporary solution shall be used. This shall be reported to the owner of the equipment so all parties are advised.

Initial safety checks shall include:

- That capacitors are discharged: this shall be done in a safe manner to avoid possibility of sparking;
- That no live electrical components and wiring are exposed while charging, reversing or purging the system;
- That there is continuity of earth bonding.

### DD.5 – REPAIRS TO SEALED COMPONENTS

DD.5.1 During repairs to sealed components, all electrical supplies shall be disconnected from the equipment being worked upon prior to any removal of sealed covers, etc. If it is absolutely necessary to have an electrical supply to equipment during servicing, then a permanently operating form of leak detection shall be located at the most critical point to warn of a potentially hazardous situation.

DD.5.2 Particular attention shall be paid to the following to ensure that by working on electrical components, the casing is not altered in such a way that the level of protection is affected. This shall include damage to cables, excessive number of connections, terminals not made to original specification, damaged to seals, incorrect fitting of glands, etc. Sealed electrical components shall be replaced. Ensure that seals or sealing materials have not degraded to the point that they no longer serve the purpose of preventing the ingress of flammable atmospheres. Replacement parts shall be in accordance with the manufacturer's specifications.

### DD.6 – REPAIR TO INTRINSICALLY SAFE COMPONENTS

Do not apply any permanent inductive or capacitance loads to the circuit without ensuring that this will not exceed the permissible voltage and current permitted for the equipment in use. Intrinsically safe components must be replaced. Replace components only with parts specified by the manufacturer. Other parts may result in the ignition of refrigerant in the atmosphere from a leak.

NOTE: The use of a silicon sealant can inhibit the effectiveness of some types of leak detection equipment. Intrinsically safe components do not have to be isolated prior to working on them.

### DD.7 – CABLING

Check that cabling will not be subject to wear, corrosion, excessive pressure, vibration, sharp edges or any other adverse environmental effects. The check shall also take into account the effects of aging or continual vibration from sources such as compressors or fans.

### DD.8 – DETECTION OF FLAMMABLE REFRIGERANTS

Under no circumstances shall potential sources of ignition be used in the searching for or detection of refrigerant leaks. A halide torch (or any other detector using a naked flame) shall not be used.

The following leak detection methods are deemed acceptable for all refrigerant systems.

Electronic leak detectors may be used to detect refrigerant leaks but, in the case of flammable refrigerants, the sensitivity may not be adequate, or may need recalibration. (Detection equipment shall be calibrated in a refrigerant-free area.) Ensure that the detector is not a potential source of ignition and is suitable for the refrigerant used. Leak detection equipment shall be set at a percentage of the LFL of the refrigerant and shall be calibrated to the refrigerant employed, and the appropriate percentage of gas (25% maximum) is confirmed.

Leak detection fluids are also suitable for use with most refrigerants but the use of detergents containing chlorine shall be avoided as the chlorine may react with the refrigerant and corrode the copper pipe-work.

NOTE: Examples of leak detection fluids are:

- Bubble method,
- Fluorescent method agents

If a leak is suspected, all naked flames shall be removed/extinguished.

If a leakage of refrigerant is found which requires brazing, all of the refrigerant shall be recovered from the system, or isolated (by means of shut of valves) in a part of the system remote from the leak. Removal of refrigerant shall be according to Clause DD.9.

**DD.9 – REMOVAL AND EVACUATION**

When breaking into the refrigerant circuit to make repairs – or for any other purpose – conventional procedures shall be used. However, for flammable refrigerants it is important that best practice is followed since flammability is a consideration. The following procedure shall be adhered to:

- Safely remove refrigerant following local and national regulations
  - Evacuate;
  - Purge the circuit with inert gas (optional for A2L)
  - Evacuate (optional for A2L);
  - Continuously flush or purge with inert gas when using flame to open circuit; and
  - Open the circuit.

The refrigerant charge shall be recovered into the correct recover cylinders if venting is not allowed by local and national codes. For appliances containing flammable refrigerants, the system shall be purged with oxygen-free nitrogen to render the appliance safe for flammable refrigerants. This process may need to be repeated several times. Compressed air or oxygen shall not be used for purging refrigerant systems.

For appliances containing flammable refrigerants, refrigerants purging shall be achieved by breaking the vacuum in the system with oxygen-free nitrogen and continuing to fill until the working pressure is achieved, then venting to atmosphere, and finally pulling down to a vacuum (optional for A2L). This process shall be repeated until no refrigerant is within the system (optional for A2L). When the final oxygen-free nitrogen charge is used, the system shall be vented down to atmospheric pressure to enable work to take place.

The outlet for the vacuum pump shall not be close to any potential ignition sources, and ventilation shall be available.

**DD.10 – CHARGING PROCEDURES**

In addition to conventional charging procedures, the following requirements shall be followed.

- Ensure that contamination of different refrigerants does not occur when using charging equipment. Hoses or lines shall be as short as possible to minimize the amount of refrigerant contained in them.
- Cylinders shall be kept in an appropriate position according to the instructions.
- Ensure that the refrigerating system is earthed prior to charging the system with refrigerant.
- Label the system when charging is complete (if not already)
- Extreme care shall be taken not to overfill the refrigerating system.

Prior to recharging the system, it shall be pressure-tested with the appropriate purging gas. The system shall be leak-tested on completion of charging but prior to commissioning. A follow up leak test shall be carried out prior to leaving the site.

**DD.11 – DECOMMISSIONING**

Before carrying out this procedure, it is essential that the technician is completely familiar with the equipment and all its detail. It is recommended good practice that all refrigerants are recovered safely. Prior to the task being carried out, an oil and refrigerant sample shall be taken in case analysis is required prior to re-use of recovered refrigerant. It is essential that electrical power is available before the task is commenced.

- a) Become familiar with the equipment and its operation.
- b) Isolate system electrically
- c) Before attempting the procedure, ensure that:
  - Mechanical handling equipment is available, if required, for handling refrigerant cylinders;
  - All personal protective equipment is available and being used correctly;
  - The recovery process is supervised at all times by a competent person;
  - Recovery equipment and cylinders conform to the appropriate standards
- d) Pump down refrigerant system, if possible.
- e) If a vacuum is not possible, make a manifold so that refrigerant can be removed from various parts of the system.
- f) Make sure that cylinder is situated on the scales before recovery takes place.
- g) Start the recovery machine and operate in accordance with instructions.
- h) Do not overfill cylinders (no more than 80% volume liquid charge).
- i) Do not exceed the maximum working pressure of the cylinder, even temporarily.
- j) When the cylinders have been filled correctly and the process completed, make sure that the cylinders and the equipment are removed from site promptly and all isolation valves on the equipment are closed off.
- k) Recovered refrigerant shall not be charged into another refrigerating system unless it has been cleaned and checked.

DD.12 – LABELLING

Equipment shall be labelled stating that it has been decommissioned and emptied of refrigerant. The label shall be dated and signed. For appliances containing flammable refrigerants, ensure that there are labels on the equipment stating the equipment contains flammable refrigerant.

DD.13 – RECOVERY

When removing refrigerant from a system, either for servicing or decommissioning, it is recommended good practice that all refrigerants are removed safely.

When transferring refrigerant into cylinders, ensure that only appropriate refrigerant recovery cylinders are employed. Ensure that the correct number of cylinders for holding the total system charge is available. All cylinders to be used are designated for the recovered refrigerant and labeled for that refrigerant (i.e. special cylinders for the recovery of refrigerant). Cylinders shall be complete with pressure-relief valve and associated shut off valves in good working order. Empty recovery cylinders are evacuated and, if possible, cooled before recovery occurs.

The recovery equipment shall be in good working order with a set of instructions concerning the equipment that is at hand and shall be suitable for the recovery of the flammable refrigerant. If in doubt, the manufacturer should be consulted. In addition, a set of calibrated weighting scales shall be available and in good working order. Hoses shall be complete with leak-free disconnect couplings and in good condition.

The recovered refrigerant shall be processed according to local legislation in the correct recovery cylinder, and the relevant waste transfer note arranged. Do not mix refrigerants in recovery units and especially not in cylinders.

If compressors or compressor oils are to be removed, ensure that they have been evacuated to an acceptable level to make certain that flammable refrigerant does not remain within the lubricant. The compressor body shall not be heated by an open flame or other ignition sources to accelerate this process. When oil is drained from a system, it shall be carried out safely.

The units listed in the table below are a Partial Unit Air Conditioner, complying with Partial Unit requirements of this Standard, and must only be connected to other units that have been confirmed as complying to the corresponding Partial Unit requirements of this Standard, UL 60335-2-40/CSA C22.2 No. 60335-2-40.

**TABLE OF CONTENTS**

**Installation Specifications ..... 9**

INTRODUCTION..... 9

MOUNTING ..... 11

LOCATION..... 11

DUCT CONNECTION ..... 12

AIR FILTRATION..... 13

PIPING ..... 14

SEQUENCE OF OPERATION ..... 19

CHECKING AIRFLOW ..... 20

CHARGING A COOLING SYSTEM ..... 20

CHARGING A HEAT PUMP SYSTEM..... 22

REFRIGERANT DETECTION SYSTEM (RDS) ..... 24

ZONED SYSTEMS..... 25

SEQUENCE OF OPERATIONS IF REFRIGERANT LEAK IS DETECTED..... 26

Certified to UL 60335-2-40  
UL 60335-1  
Conforms to CSA C22.2 #60335-2-40  
CSA C22.2 #60335-1



Unico products comply with the European regulations that guarantee product safety.



# Installation Specifications

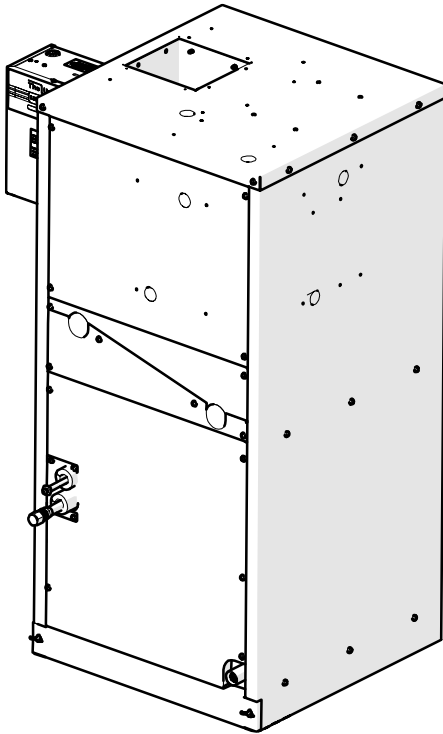

## Model Number Key

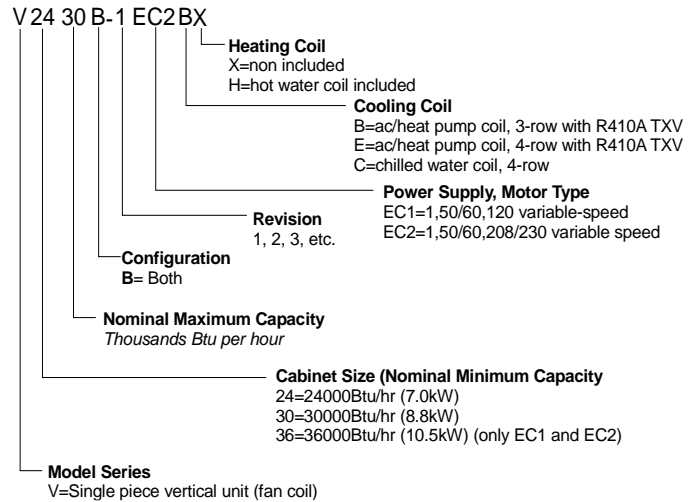

## INTRODUCTION

**General.** The information on the following pages is to help the installer save time, provide the best possible installation and insure continuous trouble-free operation.

**Scope.** These instructions apply to the Unico V2430/3036/3642 Vertical Air Handler Unit. The Unico vertical air handler unit (V-AHU) is a single packaged unit. The cooling and heating coils are contained within the same cabinet. The unit is mounted in a vertical up-flow configuration. The coils can be combined as a heating-only, cooling-only, or heating and cooling fan coil unit (see Figure 1).

The vertical unit is available in three sizes: 2430, 3036, and 3642. The heating only system includes the blower/motor and a hot water coil. The cooling only system includes the blower/motor and a cooling coil. For the heating and cooling system both coils are provided. The cooling coil is a heat pump coil (B-Style or E-Style) or chilled water coil.

All *Unico System* Vertical air handlers feature closed-cell insulation for improved sound attenuation.

The Unico System is a complete indoor comfort system that includes an indoor fan coil unit and small

duct system. The fan coil unit and duct system are designed to operate together to provide the proper airflow in every installation. The conditioned air is supplied through a series of two-inch diameter ducts as a stream of air that entrains and mixes with the room air. This process of aspiration produces a more even temperature distribution in the room than a conventional air system.

Installation instructions for the air distribution system are covered in other bulletins. Before beginning any installation, a detailed system layout must be done in accordance with *Bulletin 40-40 System Sizing and Layout bulletin*.

## SUFFICIENT BUILDING INSULATION IS ESSENTIAL FOR THE MOST ECONOMICAL OPERATION

**General Precautions and Safety Tips** Do not attempt to install or startup unit without first reading and understanding the appropriate sections in this manual. Before operating, be sure the unit is properly grounded.

- Installation should be in accordance with all local codes and regulations and with the National Fire Protection Association and Underwriters Laboratories applicable standards and regulations. In case of conflict, local codes take precedence.
- All electrical wiring should be in accordance with the latest edition of the National Electrical Code and all local codes and regulations.
- Condensate piping should be installed in accordance with governing code.
- Always install a secondary drain pan when an overflow of condensate could cause damage.

#### Options.

An electric duct heater is another option that is available to add additional features or to simplify installation. Please refer to the latest Unico Catalog for information on this and other options.

#### Temperature Limitations

The fan coil unit will operate properly under normal air conditioning and heating temperature conditions. However, there is a possibility that ice could form inside the unit under unusual conditions.

For refrigerant systems, the anti-frost switch provides some protection against frosting. It is not complete protection however. To prevent coil frosting, avoid low return air temperature below 65°F, low airflow below 200 CFM/nominal ton, low outdoor temperatures below 65°F, and especially all of these together.

Special care must be made when using water coils. The hot water coil is affected by the refrigerant coil so it is very important to verify that the air temperature leaving the refrigerant coil is always greater than 32°F. If not, or if unsure, install an averaging air temperature thermostat (Honeywell Part Number T675A1425) on the front of the hot water coil to automatically shut down the system should the air entering the hot water coil fall below 35°F. The same must be done if bringing in fresh outside air that could be below freezing.

#### WARNING!

LIMIT EWT OF HW COIL TO  
150°F-155°F (65°C-68°C)

For chilled water coils, if the unit will be installed in an area that has temperatures below freezing, then the water must be protected from freezing. The most common anti-freeze is propylene glycol or ethylene glycol mixed with water. Propylene glycol is non-toxic and must be used for food-service installation. Ethylene glycol is toxic. We recommend using corrosion inhibited glycol such as DowFrost® or DowTherm® (trademark of Dow Chemical) to increase coil life. When using propylene glycol, the coil can safely operate and survive at temperatures above the values shown in Table 1. If you use corrosion inhibited glycol, the freezing point will be a 2°F (1°C) warmer.

**Table 1. Temperature Values for Propylene Glycol**

Minimum amount (% vol) of glycol required for freeze protection.			
Lowest Expected Outdoor Temperature		Propylene Glycol†	Ethylene Glycol‡
°F	(°C)		
26	-3	11	10
20	-7	18	17
10	-12	29	27
0	-18	36	35
-10	-23	42	41
-20	-29	46	47
-30	-34	50	51
-40	-40	54	55
-50	-46	57	59
-60	-51	60	63

† Dow Chemical DOWFROST inhibited propylene glycol bulletin 180-01314-1101  
‡ Dow Chemical DOWTHERM SR-1 inhibited ethylene glycol bulletin 180-01312-602

#### Unpacking

All units are inspected prior to shipping and are carefully packaged in individual cartons. Inspect all cartons prior to unpacking. Notify carrier of any damage.

Lift up carton over the unit to reveal the unit. Inspect unit for visible signs of concealed damage and notify carrier of any such damage. All materials are sold FOB Factory and it is the responsibility of the consignee to file any claims with the delivering carrier for materials received in a damaged condition. Remove the control box from its carton sent inside the Vertical AHU carton. The expansion valve is shipped loose and is located in a separate Spare Parts box shipped inside the packaging.

## MOUNTING

There is no assembly or mounting required. The unit comes factory ready for vertical airflow applications (see Figure 1). The unit should be placed on a field fabricated plenum or directly on the floor if the floor has a return opening

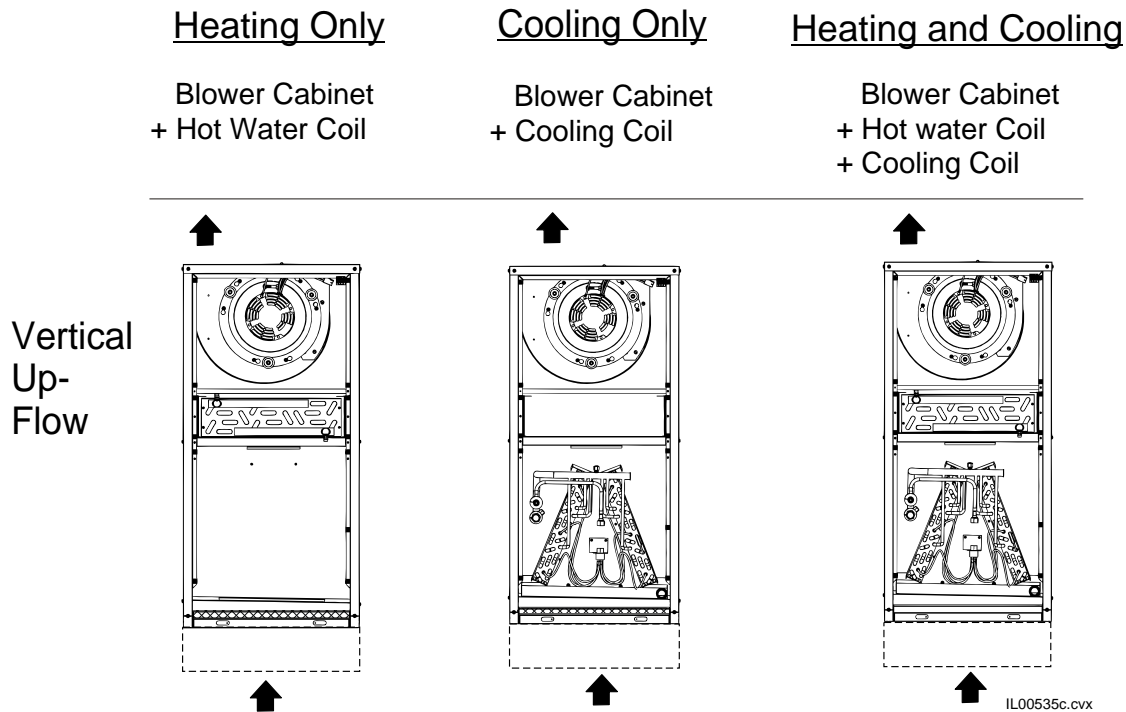

**Figure 1. Unit Arrangement**

### LOCATION

Locate the air handler to minimize the number of plenum elbows and fittings while keeping the supply duct runs as short as possible. (See *Bulletin 40-30, Component Layout*). The fully insulated cabinet allows installation with zero clearance to the top, bottom, or sides of the unit. However, clearance must be provided for servicing. All components are accessible from the front. Provide a minimum of 26 inches (660 mm) in the front. Servicing of the blower/motor assembly and coils can be performed by removing the access panels located in the front.

Each unit is designed to fit into a closet, basement or utility room (see Figure 2). The unit dimensions are shown in Table 3.

The airflow enters the bottom of the unit so either set the unit on the floor with a cutout to allow air from underneath, or set the unit on a plenum base (not provided by Unico).

**Table 2. Secondary Drain Pan (field supplied)**

Unit Size	Part No.	Dimensions inches (mm)
V2430	N/A	22 x 22 (560 x 560)
V3036	N/A	22 x 26 (560 x 660)
V3642	N/A	26 x 27 (660 x 690)

**Table 3. Unit Dimensions**

Unit Size	H	W	D
V2430	42 (1067)	20 (508)	20 (508)
V3036	42 (1067)	20 (508)	24 (610)
V3642	44 (1118)	23.75 (603)	25 (635)

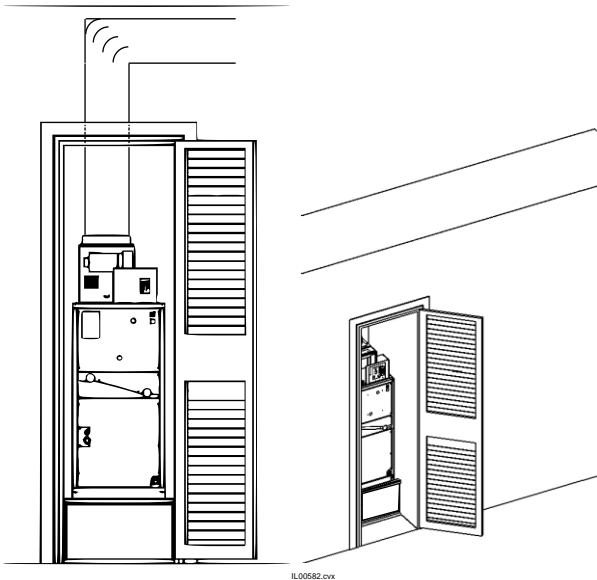

**Figure 2. Typical closed installation with ‘Wild’ return**

### Secondary Drain Pan

Where an overflow of condensate could cause water damage, a secondary drain pan **MUST BE INSTALLED**. Place the drain pan under the entire unit, including any plenum base that may be installed. Be sure to allow enough room for the drain line and connection (refer to Table 1). The unit should be placed over the secondary drain pan. Use rubber pads for isolation to raise the unit high enough in the secondary drain pan for the drain line to clear the side.

## DUCT CONNECTION

### Supply Plenum

The unit must have a plenum attached to the blower discharge. The plenum can be most any type of duct, provided it is the correct size and is insulated. The EC motor is variable speed so no restrictor plate is required. The supply duct attaches to the air handler with a supply adapter (sold separately). There are two adapters: one for square plenum and one for round. These are listed in the table below. The electric furnace, if used, includes its own supply adapter. Refer to the electric furnace installation manual for more information.

The adapter for round supply duct is a crimped metal duct transition as shown in Figure 3.

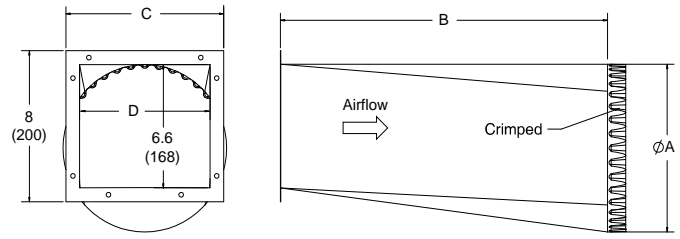

Model	Part No.	A	B	C	D
V2430	UPC-61-2430	7 (178)	12 (300)	7.5 (190)	6.0 (152)
V3036	UPC-61-3036	9 (228)	18 (450)	8.5 (215)	7.2 (183)
V3642	UPC-61-3642	9 (228)	18 (450)	8.5 (215)	7.2 (183)

Note: UPC-61-3036 and UPC-61-3642 are identical.

**Figure 3. Supply plenum adapter, round metal duct**

The square adapter is typically used with fiberglass ductboard but can be used with any square duct. The standard square adapter is designed for 1-inch (25 mm) thick ductboard. Use the R6 adapter if using 1.5 inch (38 mm) thick ductboard. The ductboard plenum should be made to fit snugly inside the adapter. See Figure 4 for standard sizes for the square adapter.

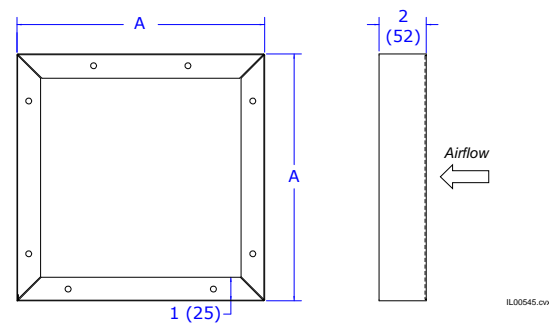

Model	Part No.	A	Part No. (R-6)	A
V2430	UPC-62-2430	8.5 (216)	UPC-62R6-2430	9.5 (241)
V3036	UPC-62-3036	10.5 (267)	UPC-62R6-3036	11.5 (292)
V3642	UPC-62-3642	10.5 (267)	UPC-62R6-3642	11.5 (292)

Note: UPC-62-3036 and UPC-62-3642 are identical.

**Figure 4. Supply plenum adapter, square duct**

To attach the plenum adapter to the unit, align the holes on the adapter with the holes located around the supply outlet on the unit. Mount the adapter with eight (8) sheet metal screws.

For metal duct, attach the plenum to the adapter by inserting it over the collar. Use three (3) or four (4) equally spaced sheet metal screws to secure the duct to the collar and then tape around the seam with UL 181A aluminum tape. Then wrap the 1-in fiberglass blanket duct insulation around the adapter and seal with UL 181A aluminum tape.

Other size plenum may be used provided it is similar in cross-sectional area. Refer to the design manual for alternate sizes.

**Return Duct**

The Unico return air system typically has a single return that includes the return air box with filter, the acoustical flex return duct, and the return air adapter. Multiple returns or extra-long returns are possible so long as the maximum pressure loss is not exceeded. The return system is designed for a maximum static pressure drop of 0.15 inches of water (37 Pa) including the filter. The return duct should have at least one 90 degree bend between the unit and filter box to reduce sound transmission directly from the unit.

The return air must always enter the unit from the bottom. Set the unit on a field fabricated duct (Figure 5) or use a field supplied plenum base. If using a duct, be sure that the inside of the duct is insulated with acoustical insulation (typically duct liner). The minimum height of the plenum duct is shown in figure 5.

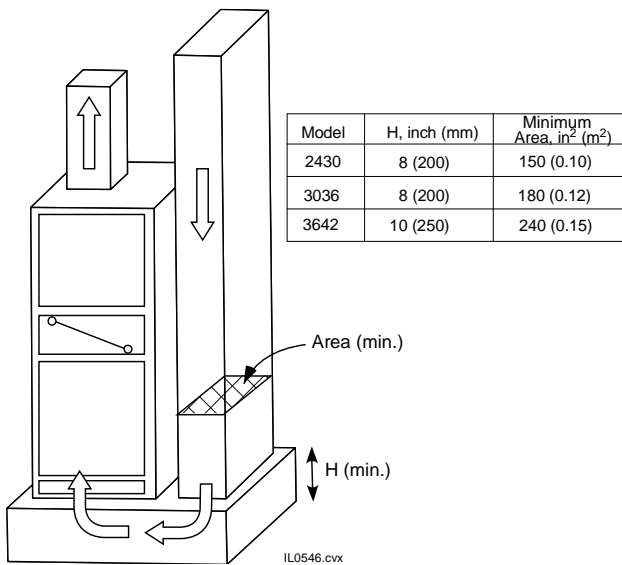

**Figure 5. Minimum duct return**

Although Unico only supplies a single return system, the return system can be redesigned for multiple returns. The return duct system is not high velocity. Therefore, the return system static pressure should not exceed 0.15 inches of water column. Generally, this means sizing the duct for a pressure loss of 0.05 inches of water column at the required airflow and sizing the filter for a pressure drop of 0.10 inches of water column at the required airflow.

It should also have some form of sound attenuation. Sound attenuation can be accomplished with fabricated

duct board, lined sheet metal, or acoustical flex. For best attenuation, always have at least one 90 degree bend to eliminate direct line-of-site from the unit to the return opening.

**AIR FILTRATION**

The unit includes a 1 inch (25 mm) thick pleated filter (Table 3). You can remove this filter (Figure 6) and replace it with a 2" filter or install another filter elsewhere in the system.

**Table 4. Unit Filter Size, 1 inch (25 mm)**

Model	Filter Part No.	Dimensions, inch (mm)
2430	A00558-005	18 x 18 (457 x 457)
3036	A00558-008	18 x 22 (457 x 559)
3642	A00558-009	21 x 22 (533 x 584)

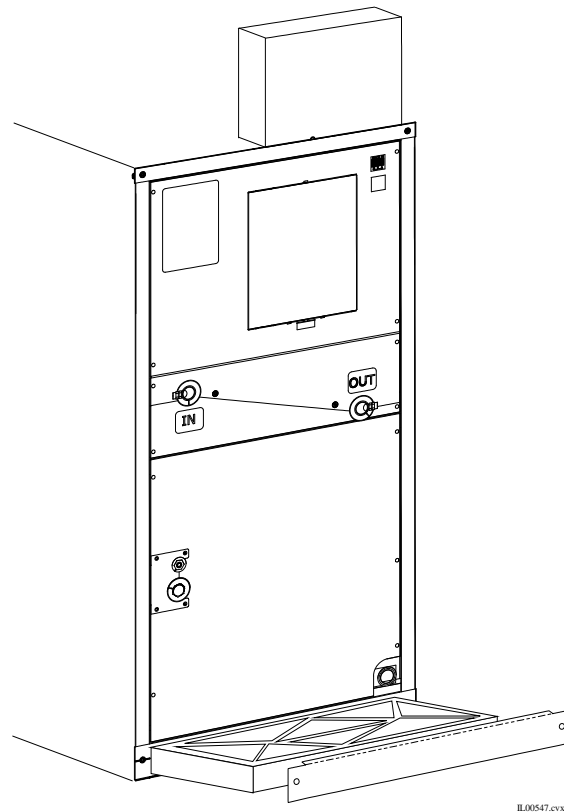
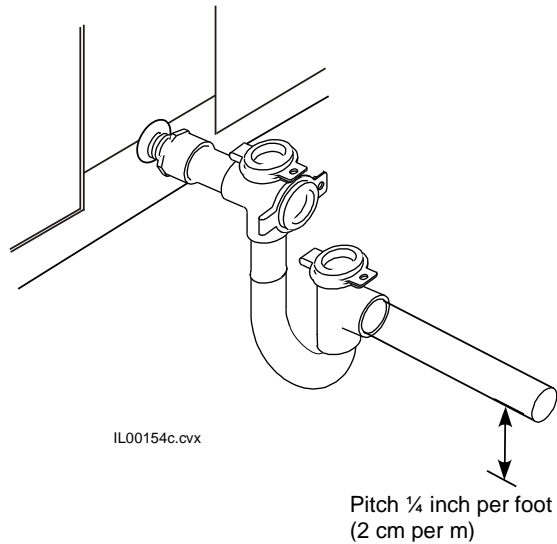

**Figure 6 Air Filter Removal**

**PIPING**

All piping must be in accordance with all local codes and ordinances.

**Condensate Lines**



**Figure 7. Typical Condensate Trap**

The primary drain pan condensate connection is a 3/4 inch (19 mm) female pipe thread fitting. Elevate the unit so the condensate lines are pitched at least 1/4 inch per lineal foot (20 mm per meter). Trap the condensate line near the unit as shown in Figure 7.

The Vertical AHU includes a condensate U-Trap which features a clear trap that is easy to visually inspect for clogs. The U-Trap is designed for the *Unico System* with a 2.5 inch (64mm) deep trap to handle the higher static pressures. The U-Traps have easy to remove clean-out caps and incorporate tees to accommodate any piping arrangement (Part No. A00924-G05).

**Refrigerant Connections**

**CAUTION: WHEN BRAZING, PURGE WITH NITROGEN GAS TO PREVENT THE FORMATION OF OXIDES.**

The refrigerant lines are copper flare connections. The sizes are shown in Table 4. Refer to the condensing unit manufacturer’s instruction for proper line sizing information based on distance from condenser.

**Table 5. Liquid and Suction line size**

Model Size	Liquid line	Vapor line
2430	1/4 Flare to 3/8” Solder	1/2 Flare to 5/8” Solder
3036	3/8 Flare to 3/8” Solder	5/8 Flare to 3/4” Solder
3642	3/8 Flare to 3/8” Solder	3/4 Flare to 3/4” Solder

Install a liquid line filter drier as close to the coil as possible to protect the evaporator from foreign object debris. For troubleshooting purposes, especially for attic installations or when using long line sets, an optional moisture indicating sight glass should also be installed between the filter-drier and expansion valve near the indoor unit (see Fig. 8).

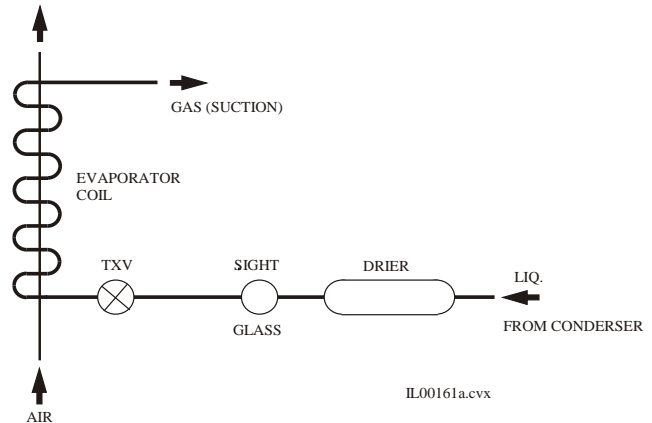

**Figure 8. Refrigeration Schematic**

## Expansion Valve

The expansion valve is shipped loose inside the spare parts box which is inside the vertical unit shipping box (for refrigerant coils only). Use the following steps when installing the TXV:

1. Remove plastic caps to external equalizer line and distributor inlet.
2. Install the white Teflon o-ring in both connections of the TXV. Attach and tighten lower connecting nut to the distributor as shown in Figure 9.
3. Connect the outlet to the 3/8" (9.5 mm) OD copper refrigerant fitting. Make sure the threaded fitting is tight (Figure 10).
4. After all lines have been connected, pressure check the connections by charging the system with 150 psig of dry nitrogen and check for leaks at all connections.

Locate the bulb at the 2 or 10 o'clock position on a horizontal straight section of the suction line. Attach the bulb to the tubing with the two pieces of cork tape that are provided. Placement is shown in Figure 11. For satisfactory expansion valve control, good thermal contact between the bulb and the suction line is essential.



**Figure 9. Attaching TXV to Distributor**



**Figure 10. Attaching TXV to Liquid Line**

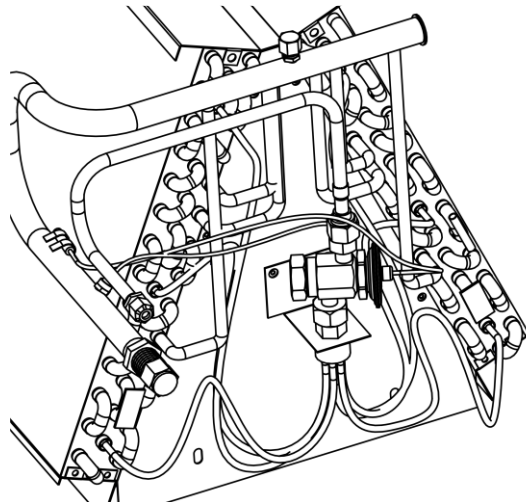

**Figure 11. TXV bulb placement**

## Water Connections

If you are installing the hot water coil, remove the side coil access panel. Slide the coil into the cabinet if not already installed at the factory and reinstall the door panel. After removing plugs in the inlet and outlet holes, caulk around connections to prevent leakage.

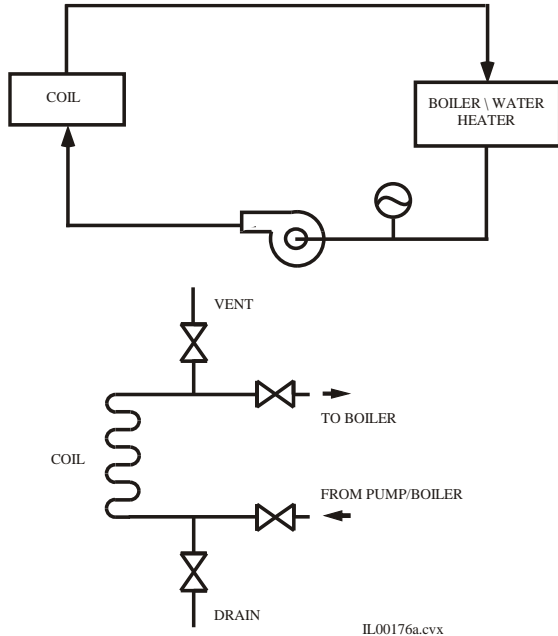

**Figure 12. Water Piping Schematic**

Pump and pipe sizing should be based on proper flow rate. Refer to Bulletin 20-019 for chilled water coil capacities based on flow rate.

Sweat the water connections, then fill the system. Install a vent valve at the highest point and a drain valve at the lowest point of the water system (refer to Fig. 12). Fill and bleed the air from the system. If unit is in an unconditioned space care must be taken to prevent the water from freezing. Use a glycol-water antifreeze solution with a freezing point below the coldest temperature expected

As an alternate to an anti-freeze solution, the water can be continuously circulated to prevent freezing. If the coil will not be used for an extended period of time during cold temperatures, drain the system then flush with a glycol solution.

## Wiring

### WARNING!

**DISCONNECT ELECTRICAL SUPPLY BEFORE WIRING UNIT TO PREVENT INJURY OR DEATH FROM ELECTRICAL SHOCK.**

All electrical wiring must comply with all local codes and ordinances. Make electrical connection in accordance with the wiring diagram shown in Figure 12 for 230V and Figure 13 for 120V. Refer to separate control box manual for additional wiring instructions.

The vertical unit uses the EC motor and SCB control as standard. The vertical unit is sold as 230V or 120V power. Use a separate 1ph, 60/50 Hz power supply with a 15 amp fuse or breaker and appropriate wire gauge per local code.

1. Connect the power supply to terminals L1 and L2/N of the terminal block.

The low voltage transformer is factory wired for a primary voltage of 230V. If power supply is 208V, move the switch on the control board to the 208 setting.

2. Connect the ground to the ground terminal.
3. Plug the motor cable to the motor.
4. Connect the anti-frost wires if using a refrigerant coil.
5. Connect the thermostat wires.
6. Connect the condensing unit wire



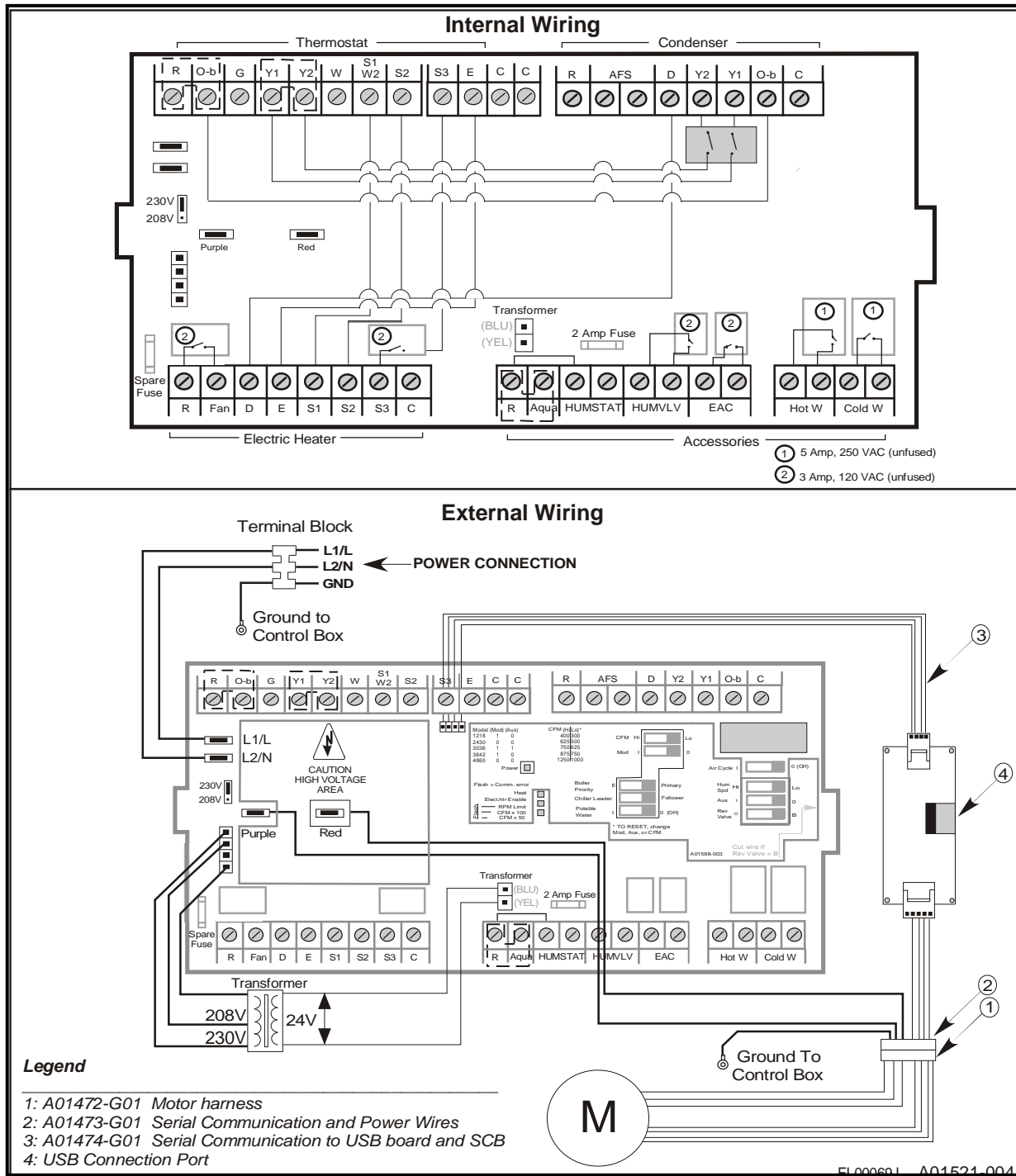

Figure 13. Wiring Schematic, 230V

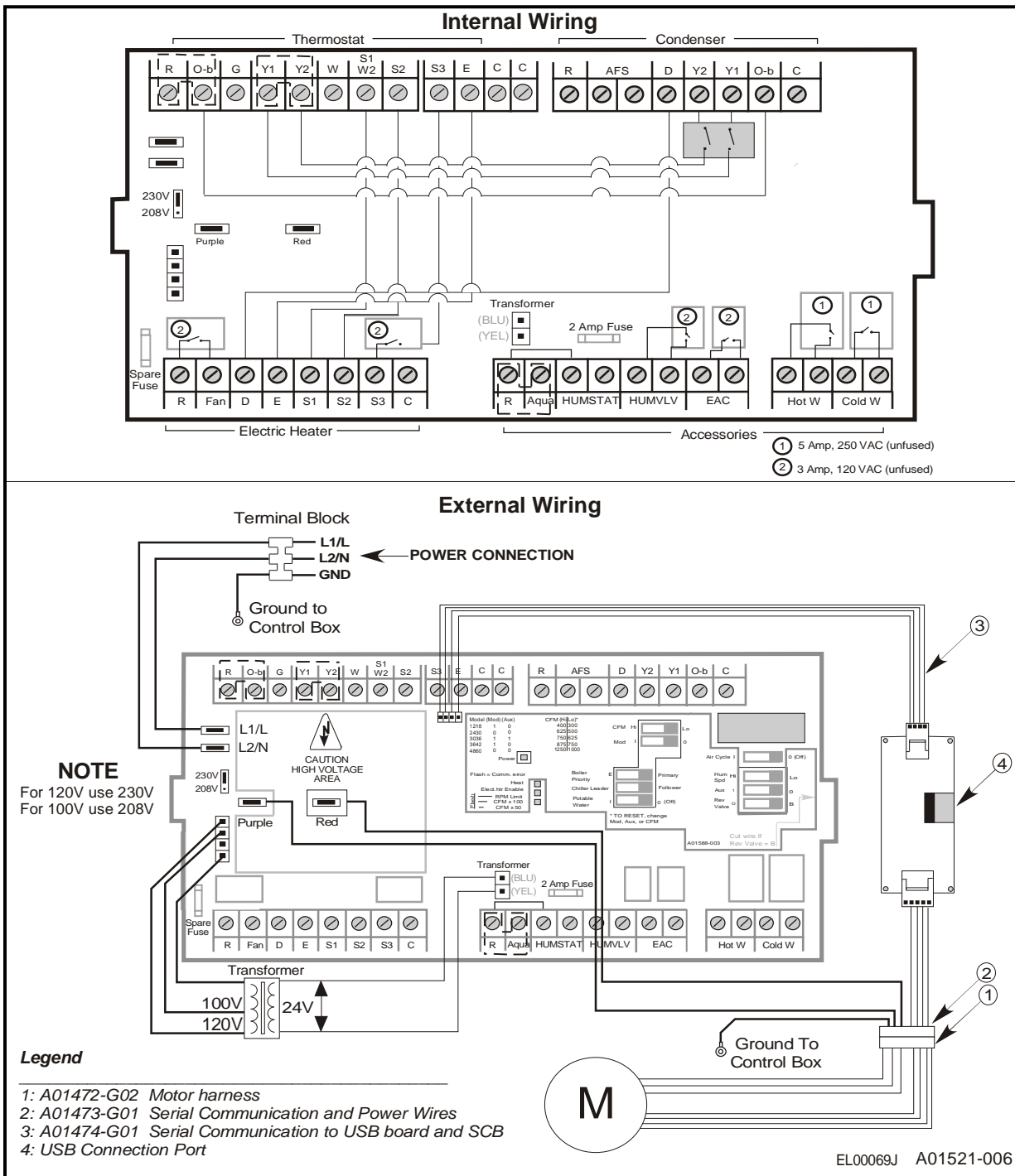

Figure 14. Wiring Schematic, 120V

## SEQUENCE OF OPERATION

The sequence of operation depends on the options installed and type of control thermostat used. Most thermostats have a fan AUTO-ON switch. When the fan switch is set to ON, the “G” circuit is closed and the blower relay is energized. The indoor blower starts after about a 45 second delay. The following paragraphs describe the sequence of operation when the fan is set to AUTO. If the fan switch is set to ON, the sequence is the same except the “G” circuit is always closed and the indoor fan is always operating.

### Cooling Cycle (A/C or Heat Pump)

When the thermostat calls for cooling, the “Y” and the “G” circuits are closed, and a 24 V signal is sent to the compressor contactor in the outdoor unit and fan relay in the indoor unit. After about 45 seconds, the indoor blower starts. At the same time, the compressor and outdoor fan also start. Depending on the control circuitry in the outdoor unit, there may be a time delay before the outdoor unit starts. If the system was just turned off, the time delay could be as much as five minutes. The cooling system is now operating.

For heat pump thermostats setting the switch to ‘cooling’ immediately closes the “O” circuit, which is used to energize the reversing valve solenoid if required by the heat pump. Otherwise, the “B” circuit, which closes when switched in heating, is used to energize the reversing valve solenoid. (Refer to the heat pump manufacturer’s instructions to see which mode the solenoid needs to be energized – whether in heating or cooling.)

When the thermostat is satisfied, the 24 V signals open and the outdoor unit stops. The indoor blower continues to operate for about 40 seconds, then stops. The system is now off.

### Heating Cycle (Heat Pump)

Setting the thermostat to HEATING will automatically switch the reversing valve solenoid. This setting closes the “B” circuit which sends a 24V signal to energize the solenoid if required by the heat pump. Otherwise the “B” circuit is not used and the solenoid is not energized during heating.

When the thermostat calls for heating, the “Y” and “G” circuits are closed, sending a 24 V signal to the compressor contactor in the outdoor unit and the fan relay in the indoor unit. This starts the indoor blower and the outdoor compressor and blower. There is a time delay of about 45 seconds for the indoor unit. The heating system is now operating in stage one.

If the first stage does not satisfy the thermostat, the second stage thermostat calls for more heat. This closes the “W2” contacts and energizes the sequencer for electric heat. When the second stage thermostat is satisfied, the “W2” circuit is broken and the sequencer is de-energized. The electric heating system is now off.

When the first stage thermostat is satisfied, the 24 V signals open and the outdoor unit stops. The indoor blower continues to operate for about 45 seconds, then stops. The system is now off.

### Cooling Cycle (Chilled Water)

When the thermostat calls for cooling, the “Y1” circuit brings on the fan at low speed and “Y2” at full speed. The chilled water relay is used to energize either a chiller, valve, or pump

When the thermostat is satisfied, the 24 V signal to the relay opens the chilled water circuit which stops the pump or closes a valve. The fan circuit opens and de-energizes the fan relay. After about 45-seconds the blower stops.

### Heating Cycle (Electric Heat)

When the thermostat calls for heating, the “W2” and “G” circuits are closed. The W2 circuit completes the 24V signal to the sequencer in the electric duct heater, which cycles on the electric heating elements. The heating system is now operating.

When the thermostat is satisfied, the 24 V signals open and the indoor blower stops after about 40 seconds. At the same time the sequencer cuts the power to the electric elements. The system is now off.

### Heating Cycle (Hydronic Heat)

When the thermostat calls for heating, the “W1” circuit brings on the fan at low speed and “W2” at full speed. The HotW relay is used to energize either a boiler, valve, or pump. For ‘combo’ systems, where potable water is circulated through the hot water heating coil, it is necessary to ensure that the water is never stagnant in the coil. The switch will activate a timer so that the HotW relay will energize a pump to circulate water once per day for 5 minutes regardless.

If an aquastat is utilized between R and aqua, the fan relay circuit will remain open until the aquastat is closed. R-Aqua allows the HotW relay to function without an optional aquastat. If an aquastat is used, this jumper must be removed.

When the thermostat is satisfied, the 24 V signal to the heat relay opens the HotW circuit which stops the pump or closes a valve. The fan circuit opens and de-energizes the fan relay. After about 45-seconds the blower stops.

## CHECKING AIRFLOW

**CAUTION. DO NOT OPERATE BLOWER WITH FREE DISCHARGE OR LOW STATIC PRESSURES (BELOW 1 INCH WC (250 Pa)) TO PREVENT MOTOR FROM OVERLOADING.**

After the system is installed and before charging system, check for proper airflow. Record the plenum static pressure. With this information, the amount of airflow can be determined by counting the flashes on the SCB.

As a recommended further check on airflow, use a velometer to measure the airflow from each outlet. The most convenient instrument to use is a handheld vane type velocity meter that fits directly over the outlet. Refer to Technote 113 for more information.

By measuring and totaling the CFM of all outlets and comparing the total to the SCB readout, one can determine whether there is gross leakage in the duct system. If the values are more than 20% or 150 CFM apart, inspect the duct system for leaks and repair. Refer to Bulletin 30-039 for checking airflow for an EC motor.

### Static Pressure

It is not necessary to measure the return duct static pressure unless it was field fabricated or the static pressure is lower than expected. That's because checking the airflow is mainly useful for determining if there is restriction in the duct.

If you are to measure the static pressure, measure the external static pressure (see figure 15) in the supply plenum at least two feet (0.6 m) from the unit and verify that it is within the allowable range.

The maximum return static pressure (including filters) should be 0.15 inches of water column (37 Pa). If it is greater than 0.15 inches of water column, add the return system pressure drop to the supply plenum static pressure to get the total static pressure drop.

**For example:** If the supply static pressure is measured to be 1.6 inches w.c. and the return system pressure drop is 0.25 inches w.c., the total static pressure drop is:  $1.6 + 0.25 = 1.85$ . In this case the static pressure is too high.

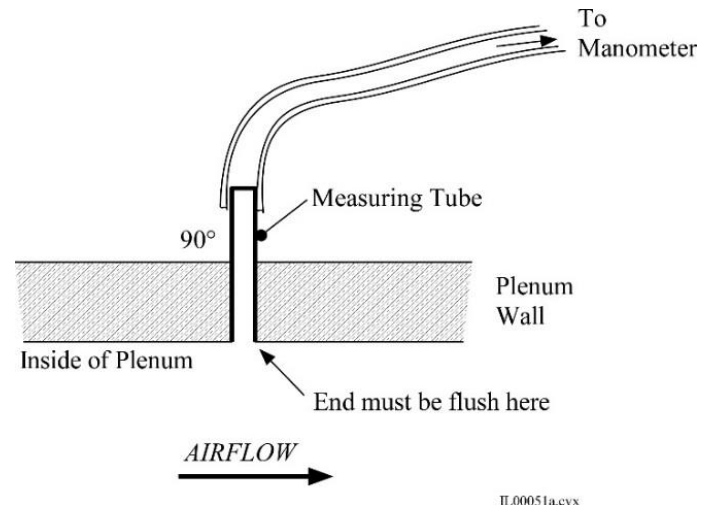

**Figure 15. Measuring Plenum Static Pressure**

## CHARGING A COOLING SYSTEM

**DO NOT VENT REFRIGERANT TO THE ATMOSPHERE!!** It is a violation of federal law and in some cases local ordinances. Always use a refrigerant recovery or recycling device.

If charging a heat pump, refer to *Bulletin 30-024, Instructions for "M" Series Modular Heat Pump Systems*. The following procedure is only valid for charging the system during the cooling mode.

To check for proper charge, record the refrigerant pressures and temperatures. Check the refrigerant charge by measuring the amount of sub-cooling (or 'approach' temperature for some condensing units). If the outdoor manufacturer does not have sub-cooling or "approach" temperature charts, then be sure that the sub-cooling is between 8 and 5 °F (2 to 5°C). For long refrigerant lines or when the evaporator is above the condenser, the sub-cooling should be close to 8°F; otherwise, aim for the low end of the range.

After the refrigerant lines and evaporator have been carefully leak tested and evacuated, release the R410A operating charge in the condensing unit. The system is now ready for refrigerant charge adjustment.

Start up the system and check line voltage to assure it is within acceptable limits for the system as dictated by the condensing unit manufacturer. Run the system for 20 to 30 minutes to get reasonably stabilized conditions. Do not attempt to adjust charge with outdoor temperature below 75°F (24 °C). An outdoor temperature of 75 to 85°F (24 to 29 °C) is preferred.

If the system charge must be checked when the outdoor temperature is below 80°F (26.7 °C), block the condenser coil until the head pressure is approximately equal to what its charging chart specifies for an 85°F (29 °C) day.

For heat pumps always check the charge in cooling mode. If this is not possible because of low outdoor temperatures, charge the system in the heating mode, but return later when the weather is warmer before the system is switched to cooling.

### Sub-cooling Method

Many condensing unit manufacturers publish the amount of sub-cooling that the condenser will produce. Follow their instructions to charge the unit. Typical sub-cooling values will be between 8 and 15°F (5 to 9 °C). The unit should ALWAYS have some amount of sub-cooling. To be sure there is enough sub-cooling, especially if the unit is in a hot attic, check the liquid line sight glass near the evaporator for bubbles or measure the refrigerant liquid line pressure and temperature AT THE EVAPORATOR.

To measure sub-cooling use the following procedure:

1. Measure and record the liquid line pressure using an accurate refrigerant gauge. Record the corresponding saturation temperature for this pressure (see Table 6).
2. Measure and record the liquid line temperature using an accurate metal or glass thermometer, or thermocouple. Tape or strap the sensor firmly against the surface of the liquid line and cover with insulation.
3. Determine the sub-cooling with the following equation:

$$\frac{\text{SATURATED TEMPERATURE}}{\text{- LIQUID LINE TEMPERATURE}} \\ \text{SUBCOOLING}$$

If the sub-cooling temperature at the condenser is low, the system is undercharged. If it is high, the system is overcharged and some refrigerant must be removed and collected in an empty refrigerant container. ***Do not vent the refrigerant; it is a violation of federal law!***

In some cases, such as in a hot attic, the liquid line will pick up heat and lose its sub-cooling. This will be apparent if the sub-cooling at the evaporator is low. In these cases, the liquid line should be insulated or strapped to the suction line and both insulated. The same problem can occur for long refrigerant lines; in this case, increase the size of the liquid line to reduce the pressure drop.

**CAUTION. TO MAINTAIN PROPER HEAT PUMP OPERATION, DO NOT STRAP THE LIQUID AND SUCTION LINES TOGETHER FOR HEAT PUMP SYSTEMS.**

### Superheat Method

Do not charge the system based on superheat. Superheat measurements should only be used to verify that the expansion valve is working properly. If it is more than expected please refer to *Tech note 114* on troubleshooting expansion valves.

The superheat should be between 8 to 12°F (4 to 7°C) at the indoor coil. In some cases, particularly for the larger capacity match-ups (i.e. 3 ton and 5 ton), a superheat of 15 to 18°F (8 to 10°C) is satisfactory. It is not uncommon to measure a superheat above 20 to 25°F (11 to 14°C) at the condensing unit.

Be aware that the superheat value is also dependent on the outdoor air temperature. At lower air temperatures the superheat will be higher than at higher air temperatures. If the condenser ambient temperature is between 75 and 85°F (24 to 29°C), superheat should be approximately 10 to 12°F (5 to 7°C). If the outdoor temperature is between 85 and 105°F (29 to 40°C), superheat should be approximately 8 to 10°F (4 to 5°C).

To measure the superheat use the following:

1. Measure and record the suction pressure at the evaporator outlet using an accurate refrigerant gauge. If this is not possible, measure the pressure at the service port on the suction valve fitting at the condensing unit and add the estimated pressure loss in the suction line between the condensing unit and evaporator. Record the corresponding saturation temperature for this pressure (see Table 6).
2. Measure the suction line temperature at the evaporator outlet using an accurate metal or glass thermometer, or thermocouple. Insert the thermometer under the insulation on the suction line and tape firmly against the surface of the suction tube.
3. Determine the superheat with the following equation:

$$\begin{array}{r} \textit{Suction Line Temperature} \\ - \textit{Saturated Temperature} \\ = \textit{Superheat} \end{array}$$

### Charging by Gauge Pressures

It is not possible to charge the system by gauge pressures. Gauge pressure should only be used to verify the system is working properly

The Unico System will show a lower suction pressure during the cooling mode than a conventional system. Generally, it will be 10 to 15 psi (70 to 100 kPa) less. For example, a normal suction pressure for the Unico System will be about 65 psig (450 kPa) with an 85 to 95°F (29 to 35°C) outdoor temperature. Expect lower pressures when the outdoor temperatures are lower.

The head pressures should be similar to a conventional system when in the cooling mode.

### Using a Low Ambient Control Kit

Since the Unico System operates at colder coil temperatures (in cooling mode), an anti-frost switch is installed on the coil to prevent coil freeze-up. In certain instances, such as when the outdoor ambient temperature is low, the condensing unit will cycle on the anti-frost switch. This may reduce the cooling capacity at a time when the cooling load is still fairly high. To provide better control and comfort, install a *low ambient control* on the condensing unit. Typically, a low ambient control is necessary when operating the unit at outdoor temperatures below 70°F (21.1 °C).

These controls come in different configurations such as the Hoffman Controls Corp. series 800AA head pressure control. This control modulates the outdoor blower to maintain a minimum liquid line temperature. Other controls may cycle the fan on off. In either case, check with the condensing unit manufacturer to determine what controls are compatible with the condensing unit.

## CHARGING A HEAT PUMP SYSTEM

### Charging in Cooling Mode

Charging a heat pump, by its nature, is more difficult than a cooling-only refrigerant system. Quite often the ideal charge for cooling is different than the ideal charge for heating, making the system much more sensitive to the amount of charge. In some cases, the compressor will trip on high head pressure during the heating mode because it is overcharged if the system was charged during cooling. Likewise, the system may cycle on the anti-frost control because of a low refrigerant charge if the system was charged during heating.

To compensate for this charge difference some outdoor unit manufacturers have a charge compensator device that stores charge while in heating mode. Unfortunately there are no add-on devices to accomplish the same thing and only a few (usually the most expensive) model lines will have one. For this reason, it is often necessary to compromise the charge.

Although the unit can be charged in the heating mode, it is best to charge the unit during the cooling mode as described earlier. Then recheck the charge in the heating mode to be sure the system is not over charged.

**Charging in Heating Mode**

If the system is started up on heating where the return air temperature is significantly lower than the normal operating range of 65 to 75 °F (18.2 to 23.8 C), the suction pressure can be very low. Operate the system to bring up the return air temperature, using auxiliary heat if necessary, before checking system charge.

In heating mode, the Unico System will have a slightly higher discharge (LIQ.) pressure than a conventional system, usually about 40 to 50 psig higher. It is this higher pressure that produces a warmer air temperature; preventing “cold blow”, where the house is being heated with an air stream that feels cold.

Some outdoor heat pump units include a manual high-pressure switch. It is important that the system be operated at pressures below the trip pressure of the high-pressure switch to avoid nuisance shut downs. If this occurs, use a high head kit as described below

**Using a High Head Kit (Mild Weather Kit)**

When any heat pump is operated during mild weather (temperatures above 50°F (10 C)), the compressor may trip out on the high pressure limit. The Unico System is particularly sensitive to this since it operates at a higher pressure.

To overcome this problem, install a mild weather kit (UPC-65X) to cycle the outdoor fan based on the compressor discharge pressure. However, be sure this control is compatible with the outdoor heat pump section being used.

**Table 6. R454B and R32 Saturation Pressure - Temperature**

°F (°C)	psig (kPa)	
	R454B	R32
0 (-18)	46.1 (318)	63.4 (437)
2 (-17)	48.6 (335)	65.8 (454)
4 (-16)	51.2 (353)	68.3 (471)
6 (-14)	53.8 (371)	73.4 (506)
8 (-13)	56.6 (390)	76.1 (524)
10 (-12)	59.5 (410)	78.8 (543)
12 (-11)	62.4 (430)	81.6 (563)
14 (-10)	65.4 (451)	84.5 (583)
16 (-9)	68.5 (472)	87.5 (603)
18 (-8)	71.7 (494)	90.5 (624)
20 (-7)	75.0 (517)	93.6 (646)
22 (-6)	78.4 (541)	96.9 (668)
24 (-4)	81.8 (564)	103.5 (714)
26 (-3)	85.4 (589)	107.0 (738)
28 (-2)	89.1 (614)	110.6 (762)
30 (-1)	92.9 (641)	114.2 (787)
32 (0)	96.8 (667)	117.9 (813)
34 (1)	100.7 (694)	121.8 (840)
36 (2)	104.8 (723)	125.7 (867)
38 (3)	109.0 (752)	129.7 (894)
40 (4)	113.3 (781)	133.8 (923)
42 (6)	117.8 (812)	142.3 (981)
44 (7)	122.3 (843)	146.8 (1012)
46 (8)	126.9 (875)	151.3 (1043)
48 (9)	131.7 (908)	155.8 (1074)
50 (10)	136.6 (942)	160.6 (1107)
55 (13)	149.4 (1030)	175.3 (1209)
60 (16)	162.9 (1123)	191.2 (1318)
•	•	•
•	•	•
•	•	•
90 (32)	262.5 (1810)	294.3 (2029)
95 (35)	282.5 (1948)	317.6 (2190)
100 (38)	303.6 (2093)	342.3 (2360)
105 (41)	325.7 (2246)	368.2 (2539)
110 (43)	348.9 (2406)	386.5 (2665)
115 (46)	373.4 (2575)	415.1 (2862)
120 (49)	399.1 (2752)	445.1 (3069)
125 (52)	426.0 (2937)	477.0 (3289)
130 (54)	454.2 (3132)	499.1 (3441)

## REFRIGERANT DETECTION SYSTEM (RDS)

Each coil unit is equipped with the following components which make up the Refrigerant Detection System (RDS):

- Refrigerant Leak Detection Sensor (R-454B/R-32)
- Refrigerant Leak Mitigation Control Board and Enclosure
- Sensor to Mitigation Control Board Cable (8ft)

The Refrigerant Leak Detection Sensor comes factory mounted on the drain pan inside the coil section of the unit. The Mitigation Control Board, Control Board Enclosure, and Cable are shipped loose inside the unit. These components will need to be wired after the Control Box has been wired. See Bulletin 30-039 for instructions on how to wire the Control Box.

### SETUP

**WARNING**  
**DISCONNECT ELECTRICAL SUPPLY**  
**BEFORE WIRING UNIT TO PREVENT**  
**INJURY OR DEATH FROM**  
**ELECTRICAL SHOCK.**

1. Mount the Mitigation Control Board Enclosure near the location the Control Box is mounted using (2) #10-16 x 1/2in sheet metal screws. Mounting holes for the Enclosure can be found near the mounting holes for the Control Box on the top of the unit.

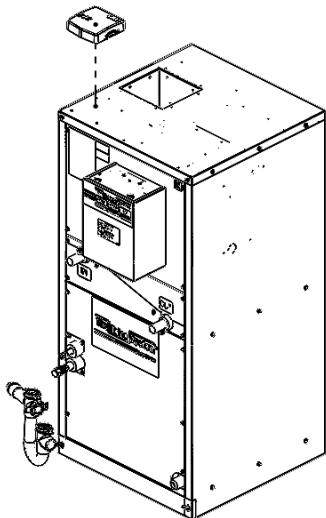

**Figure 16. Mitigation Board Enclosure Mounting**

2. Mount the Mitigation Control Board inside the Enclosure by aligning the tabs and pressing firmly until the Control Board snaps in place

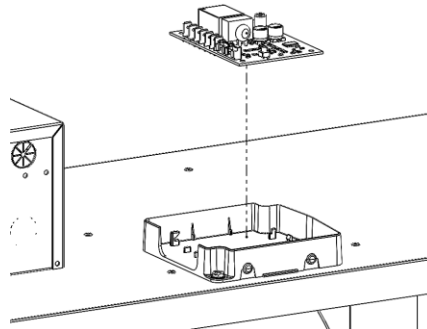

**Figure 17. Mitigation Board Mounting**

3. Remove the blower section door panel from the unit. Attach the sensor cable to the sensor which will be mounted to a bracket attached to the drain pan near the condensate connection.

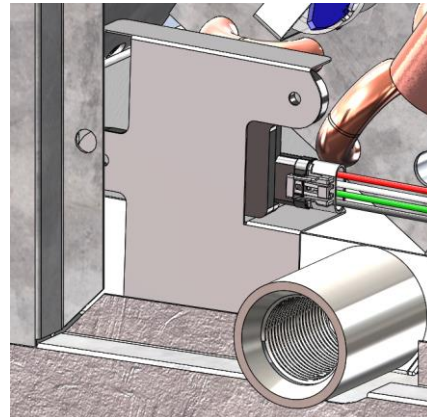

**Figure 18. Sensor Cable Attachment to Sensor**

4. Attach the opposite end of the cable to the Mitigation Control Board inside the Enclosure

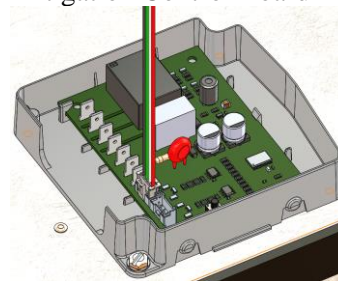

**Figure 19. Sensor Cable Attachment to Mitigation Board**



5. Next, the mitigation board will need to be wired to a thermostat and Unico Control Board. Figure 21 shows the standard wiring diagram for the RDS for most installations. Figure 20 shows an example of the Sensor Cable routing.

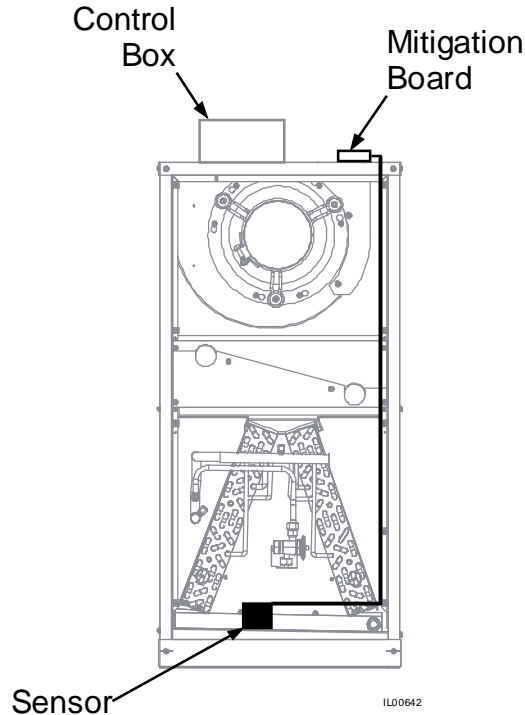

Figure 20. Mitigation to Sensor Wiring

6. Power the system and confirm the status of the system using the on-board LED lights (Table 7)

Table 7. Mitigation Board LED Codes

Status LED	Mode
Off	Normal Operation
On	Sensor “warm up”
1-blink	LFL Fault
2-blink	Communication Fault

7. Test the system to confirm the system operates appropriately. With the system powered but not running, and no call from the thermostat, disconnect the sensor cable from the sensor. This will initiate the RDS mitigation protocol and energize the G terminal to deliver the minimum circulation airflow. The fault should be confirmed by 1 blink on the Mitigation Board as stated in Table 7. Plugging in the Sensor should clear the fault and resume normal operation.

## ZONED SYSTEMS

For systems that employ zone dampers, refer to the damper manufacturer’s wiring diagram to ensure that the zone dampers open in the event of a refrigerant leak.

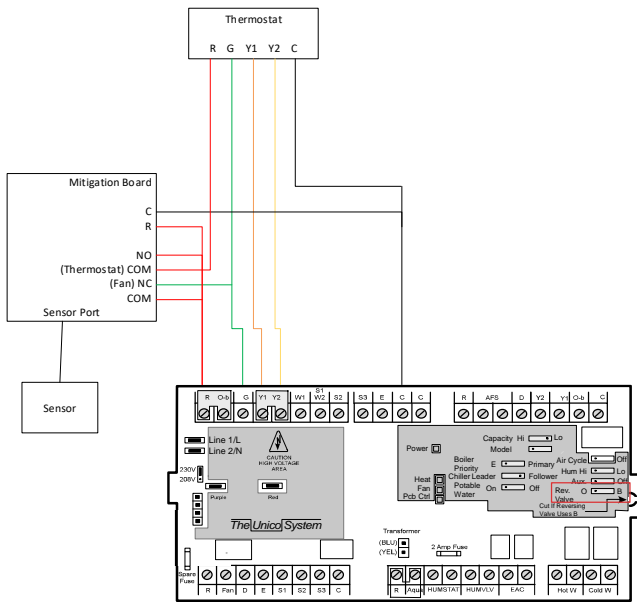

Figure 21. Leak Detection System Wiring Diagram

**\* IMPORTANT \***

For each installation, the charge of the system will dictate the minimum total room area of the conditioned space ( $TA_{min}$ ) and the minimum circulation airflow of fan mode ( $G_{min}$ ). See Bulletin 30-039 for instructions on how to set the fan mode airflow. As long as the room area of the conditioned space exceeds the value of  $TA_{min}$  listed in Table 8 for the corresponding system refrigerant charge, no additional mitigation means are required. However, if the room area of the conditioned space is **NOT** greater than the value of  $TA_{min}$  listed in Table 8 for the corresponding system refrigerant charge, additional mitigation means are required. Examples of additional mitigation include energy recovery makeup air units which is operated continuously or is triggered by the RDS, or some other ventilation method which provides outside air to the conditioned space. For example, if the charge of a system is 9.5 lb (4.3 kg) of refrigerant, and the total room area of the conditioned space is 140 ft<sup>2</sup>, no additional mitigation is required. If the total room area of the conditioned space is 135 ft<sup>2</sup>, additional mitigation is required.

### SEQUENCE OF OPERATIONS IF REFRIGERANT LEAK IS DETECTED

If a refrigerant leak is detected by the Refrigerant Detection System, the following actions will be taken:

1. Refrigerant leak (LFL fault) is detected by Refrigerant Detection System and mitigation protocols are initiated. If the unit is running, cooling or heating calls from the thermostat will be terminated by cutting power (R) to thermostat. This will turn off the compressor in the ODU and turn off the Electric Heater (if installed).
2. Unit will run in fan mode (G) until the fault has cleared plus an additional 5 minutes. If another fault occurs in this time, the mitigation protocol starts over.
3. Once the fault has cleared and the additional 5 minutes is completed, normal operation resumes.

**Table 8. Minimum Conditioned Total Room Area, Minimum Fan Mode Airflow Values**

Refrigerant Charge		Minimum Area of Conditioned Space		Minimum Circulation Airflow	
kg	Lbs	m <sup>2</sup>	ft <sup>2</sup>	m <sup>3</sup> /h	CFM
1.5	3.3	4.4	47.8	147	86
1.7	3.7	5.0	54.2	166	98
1.9	4.2	5.6	60.6	186	109
2.1	4.6	6.2	66.9	205	121
2.3	5.1	6.8	73.3	225	132
2.5	5.5	7.4	79.7	244	144
2.7	6.0	8.0	86.1	264	155
2.9	6.4	8.6	92.4	283	167
3.1	6.8	9.2	98.8	303	178
3.3	7.3	9.8	105.2	322	190
3.5	7.7	10.4	111.6	342	201
3.7	8.2	11.0	117.9	362	213
3.9	8.6	11.5	124.3	381	224
4.1	9.0	12.1	130.7	401	236
4.3	9.5	12.7	137.1	420	247
4.5	9.9	13.3	143.4	440	259
4.7	10.4	13.9	149.8	459	270
4.9	10.8	14.5	156.2	479	282
5.1	11.2	15.1	162.6	498	293
5.3	11.7	15.7	168.9	518	305
5.5	12.1	16.3	175.3	537	316
5.7	12.6	16.9	181.7	557	328
5.9	13.0	17.5	188.1	577	339
6.1	13.4	18.1	194.4	596	351
6.3	13.9	18.7	200.8	616	362
6.5	14.3	19.2	207.2	635	374
6.7	14.8	19.8	213.6	655	385
6.9	15.2	20.4	219.9	674	397

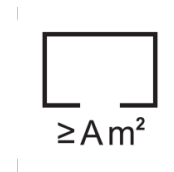

Units that show the above symbol indicate that the appliance has a requirement for a minimum room area based on system charge. Refer to Table 8 to determine the minimum total room area of the conditioned space as dictated by the system refrigerant charge.